



**2.9. KRP4A51-52-53-54 – Group control adapter PCB (installation box is necessary)**

**Accessories** Check if the following accessories are included in the kit.

Adapter	Relay harness
x 1 	(1) x 1 each  (2) x 1 each 

PC board support	x 4
Tire wrap	x 3
Installation manual	x 8

FXYC(P).....KRP1B96  
 FXYF(P).....KRP1C98  
 FXYH(P).....KRP1C93

- NOTES**
- Kits vary according to applicable models.
  - A special adapter fixing plate and box are required for the following models.

**1 SYSTEM OUTLINE**

This kit enables remote control (ON/OFF control, temperature setting, operation display, error display) and can be used with the following systems though it cannot be used in conjunction with other optional controllers for centralized control.

1. Individual control (Each indoor unit is controlled individually.)

This system requires the following parts.

- Adapter ..... KRP4A51 • 52 • 53 Any one kit
- Remote control ..... BRC1B(A)51 • 52 • 61 • 62 (For operation control) or BRC2A51 or BRC3A61 Any one kit  
 (Ex.)When individually controlling 8 FHYC71F units  
 KRP4A51 x 8 kits  
 BRC1B61 x 8 kits

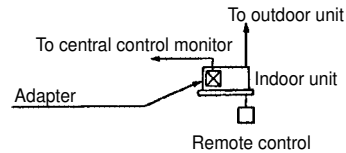

2. Group control (Multiple Indoor units are controlled as a group.)

This system requires the following parts.

- Adapter ..... KRP4A51 • 52 • 53 Any one kit
- Remote control (For operation control) ..... BRC1B(A)51 • 52 • 61 • 62 or BRC2A51 or BRC3A61 Any one kit

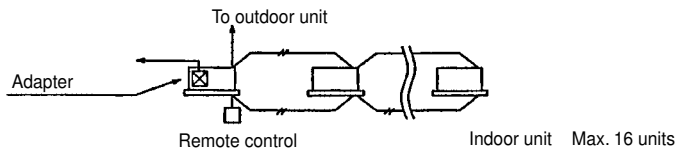

(B0121)

## 2 NAMES OF PARTS AND FUNCTION

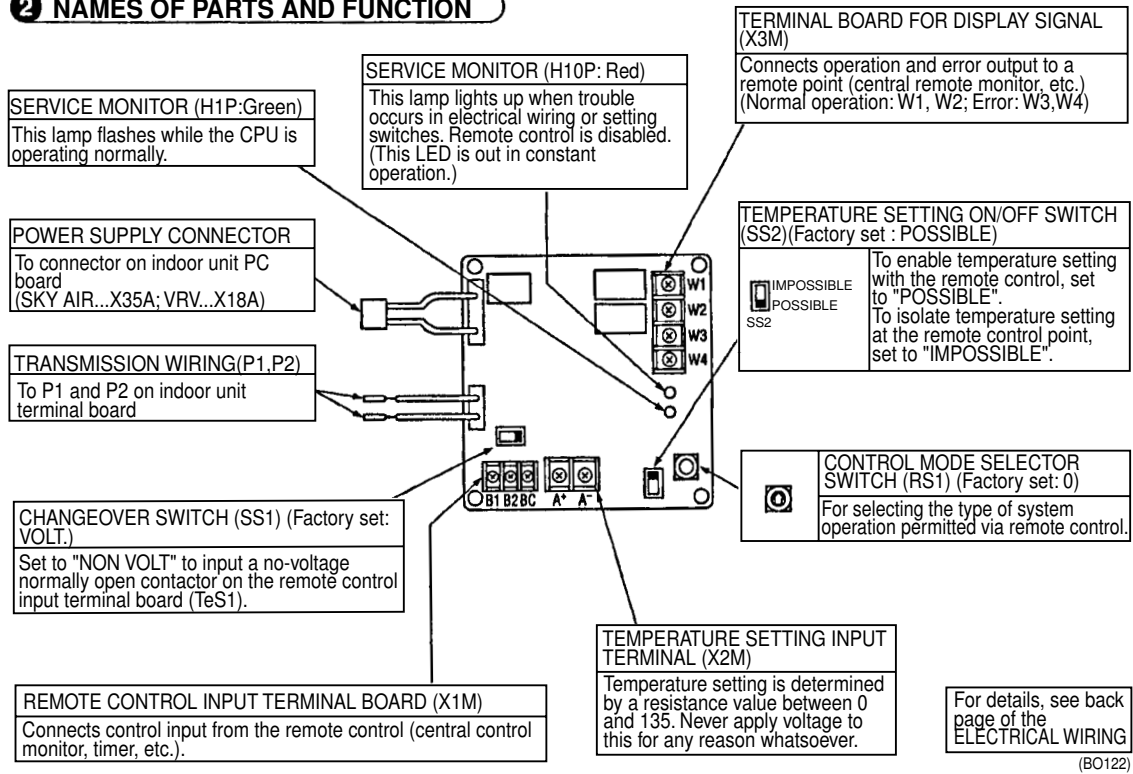

### 3 INSTALLATION

#### ◁ Ceiling mounted cassette type ▷

**FH(Y)C** (Multiflow type)

Fit the edge of the adapter PCB into the grooves on the adapter box.

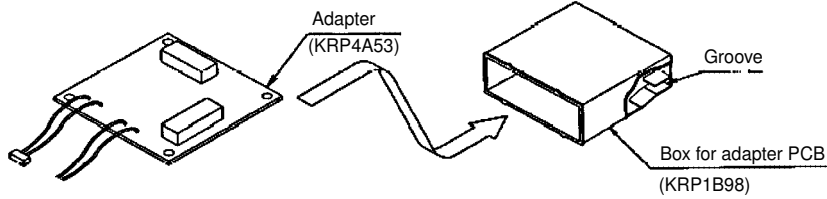

NOTE: Optional adapter box is required to install the adapter

#### ◁ Concealed ceiling ▷

**FH(Y)B**

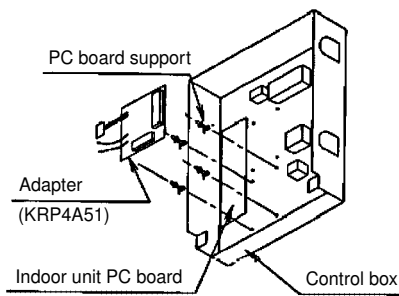

#### ◁ Ceiling suspended type ▷

**FH(Y)**

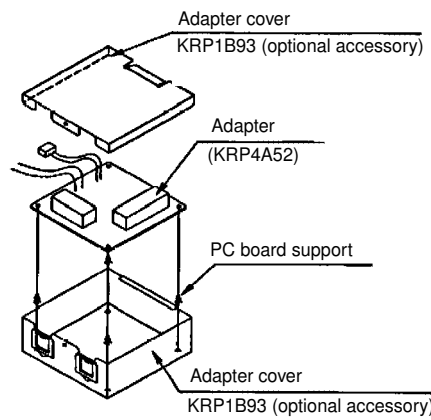

NOTE: Optional adapter box is required to install the adapter

**FH(Y)K** (Corner type)

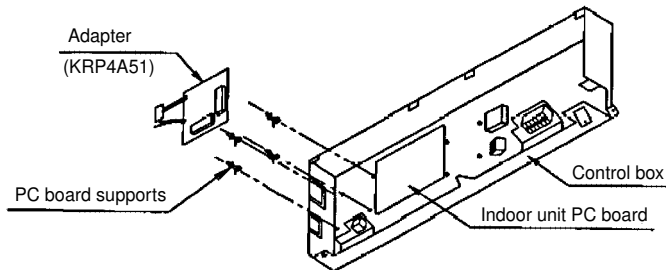

◀ Floor standing type ▶

**FVY**

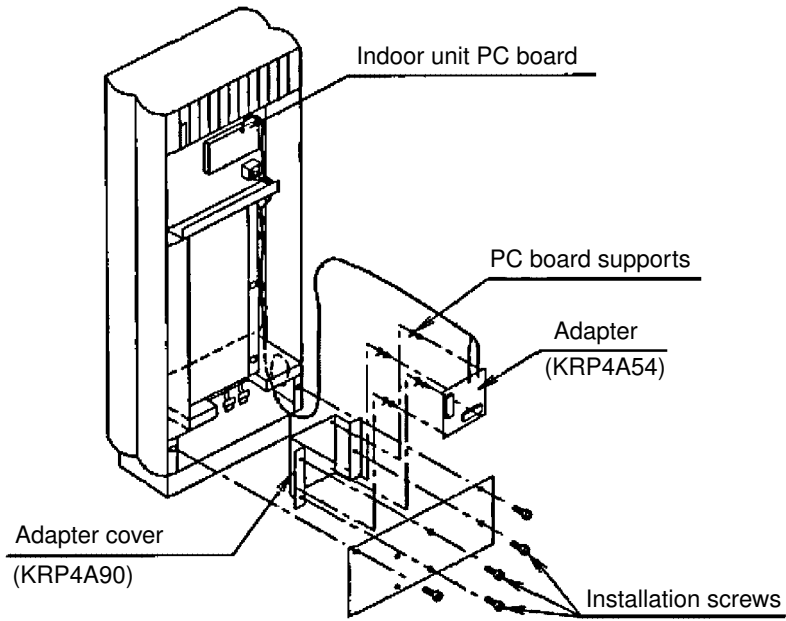

Note: optional adaptor box is required to install the adapter

◀ Wall mounted type ▶

**FA(Y)**

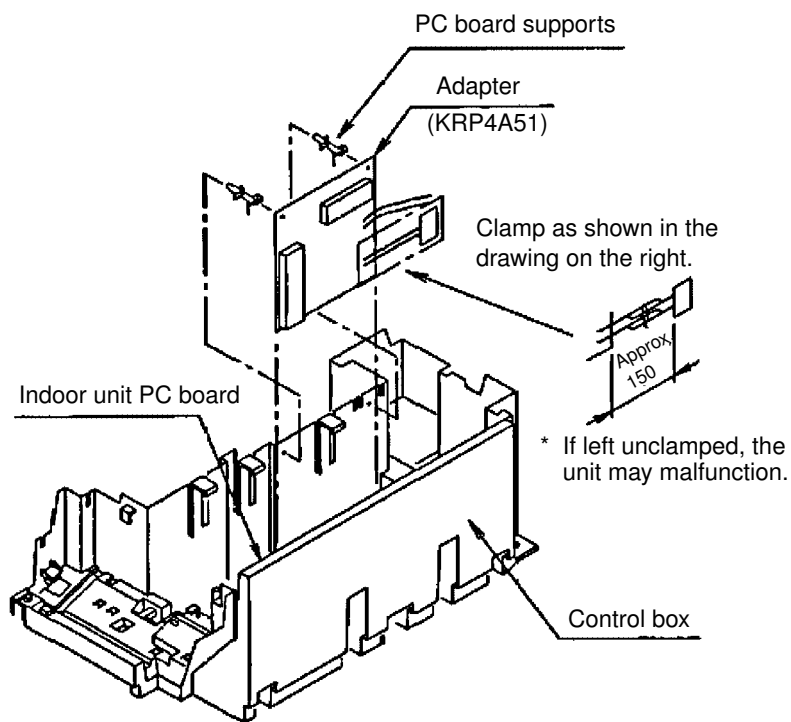

## 4 ELECTRICAL WIRING

- ① First, wire between the indoor and outdoor units, and then to the separate power sources, and finally between the indoor units and the remote controllers. Then, check if they operate properly. (If wiring for group control by remote control, check crosswires.)  
For details, see the installation manual of the indoor and outdoor units.
- ② Next, wire between outside units such as the central control monitor etc. and make the necessary settings.  
For details see [Wiring to outside units \(central control monitor\)](#)

### Wiring to indoor units

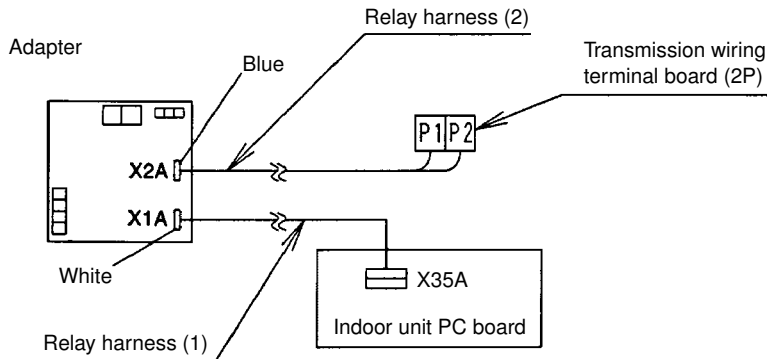

Make connections as shown above, using the attached relay harnesses (1) and (2).

- Connect relay harness (1) to the connector (X35A) on the indoor unit PC board.
- Relay harness (2) has no polarity. Connect it to terminals P1 and P2 on the transmission wiring terminal board inside the indoor unit control box.

### Wiring to outside units (central control monitor)

#### 1. Remote control input (operation control)

Wire as described below. Wiring differs depending on whether using a voltage or no-voltage input.

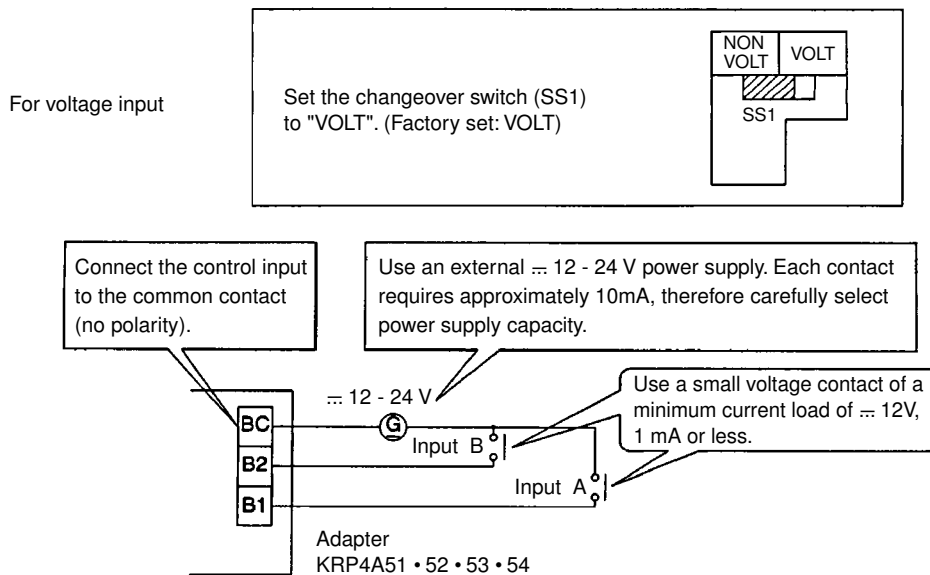

For NON VOLT Input

Set the changeover switch (SS1) to "NON VOLT"

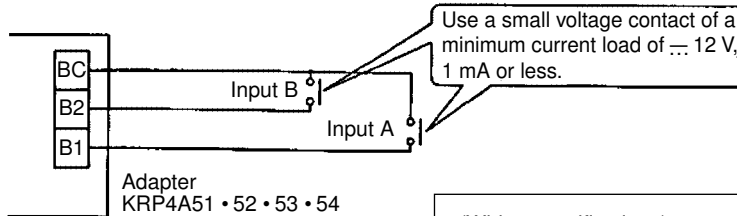
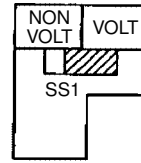

Use a small voltage contact of a minimum current load of ... 12 V, 1 mA or less.

(Wiring specifications)  
 Wiring ..... Sheathed vinyl cord or cable  
 Gauge ..... 0.18 ~ 1.25 mm<sup>2</sup>  
 Length ..... Max. 150 m  
 <NOTE >  
 Keep transmission wiring away from power supply wiring to avoid malfunctions.

**2. Setting the control mode selector switch (RS1)**

Using the control mode selector switch (RS1), select the control mode as described below.



(Factory set)  
 "0" position

① For specifying individual display

Position	Function
0	Individual display (input ignored)

② When operating the unit with constant input at input A

Position	Function	When input A is ON	When input A is OFF
1	ON/OFF control impossible by remote control	Operation (normally ON/OFF control impossible by remote control)	OFF + ON/OFF control impossible by remote control
2	Centralized	Operation + ON/OFF control possible by remote control	
3	OFF control possible by remote control	Operation + OFF control possible by remote control (ON control impossible by remote control)	
4	ON/OFF control possible by remote control	ON/OFF control possible by remote control (Operation impossible by optional control)	

<NOTE >

- Input B is for forced ON/OFF input. When input B is ON, OFF control possible but ON/OFF control by the remote control is impossible and input A is ignored. When it is OFF, input A is ignored even if selected. It is necessary to reselect input A.

- ③ When operating the unit using instantaneous input at input A  
(Use an instantaneous input of 200 msec or longer ON time.)

Position	Function	Input A	Input B capacity
5	ON/OFF control impossible by remote control	Turns OFF system with ON input Turns ON system with ON input	Input B is for forced OFF input (when ON, OFF control is possible but ON/OFF control by remote control is impossible, and input A is ignored).
6	Individual	Turns OFF system with ON input Turns ON system with ON input (Normally ON/OFF control possible by remote control)	

- ★ For thermostat control using input B

Position	When input A is ON	When input B is ON
C	ON/OFF control impossible by remote control (Same as position 5)	Forced thermostat OFF command
D		Energy saving command
E	Individual (Same as position 6)	Forced thermostat OFF command
F		Energy saving command

- Forced thermostat OFF command  
Indoor unit fan only operates.
- Energy saving command  
The indoor unit operates at 2°C higher(cooling)/lower(heating)the set temperature.

<NOTE >

- In such case, even if input A is ON, thermostat control is turned OFF, and all units in the same group will stop.

- ④ When operating the unit using instantaneous input at input A and B  
(Use an instantaneous input of 200 msec or longer ON time.)

Position	Function	When input A is ON	When input A is OFF
7	ON/OFF control impossible by remote control	Operation (normally ON/OFF control impossible by remote control)	OFF + ON/OFF control impossible by remote control
8	Centralized	Operation + ON/OFF control possible by remote control	
9	OFF control possible by remote control	Operation + OFF control possible by remote control (ON control impossible by remote control)	
A	ON/OFF control possible by remote control	ON/OFF control possible by remote control (Operation impossible by optional control)	
B	Individual	Operation (normally ON/OFF control possible by remote control)	OFF (normally ON/OFF control possible by remote control)

<NOTE >

- When set to position 7-A, and using the constant mode for input B, forced stop capacity is enabled (input A is ignored).
- At position B, the constant mode for input B is not used.

### 3. Temperature setting input

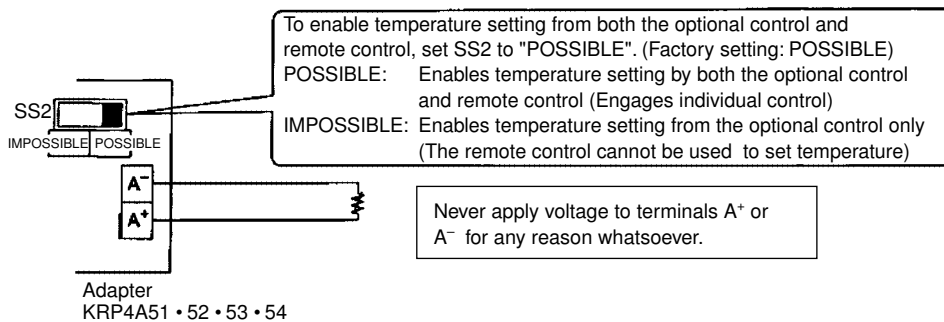

Temperature setting corresponds to resistance values in the range of 0 to 135Ω as shown below.

Temperature setting (°C)	16	17	18	19	20	21	22	23	24
Resistance (Ω)	0.0	5.0	13.8	22.4	31.0	39.4	48.2	56.6	65.2
	3.4	11.6	20.0	28.4	36.4	44.8	52.8	61.2	69.4

Temperature setting (°C)	25	26	27	28	29	30	31	32
Resistance (Ω)	73.8	82.4	91.0	99.4	108.6	117.2	125.8	134.2
	77.8	85.8	94.0	102.2	110.4	119.2	127.4	140.0

NOTE: Line resistance included in above figures

(Wiring specifications)	<NOTE>
Wiring ..... Sheathed vinyl cord	Keep transmission wiring away from power supply wiring to avoid malfunctions.
Gauge ..... 1.25 - 2.00 mm <sup>2</sup>	
Length ..... Max. 70 m	

#### 4. Canceling display signals

Operation output terminals (W1 and W2) and error output terminals (W3 and W4) are no-voltage normally constant contacts.

(Allowed electric current per contact is between 10 mA and 3 A.)

Normal operation output (Ry1)  
ON when the indoor unit is operating normally.

Error output (Ry2)  
ON when the indoor unit stops because of malfunction or when a transmission error occurs between the adapter and the indoor unit.

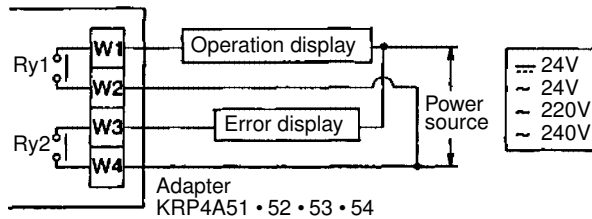

<NOTE>  
If using a 220 or 240 V power supply, keep transmission wires away from incoming power supply wiring.

Display output is as described below.

Output	Both Ry1 and Ry2 OFF	Only Ry1 ON	Only Ry2 ON
Display	OFF	Normal operation	System stopped due to malfunction or transmission error generated between adaptor and indoor unit